

## Shallow geothermal energy – history, development, current status, and future prospects

Burkhard Sanner

Wacholderbusch 11, 35398 Giessen, Germany

sanner@sanner-geo.de

**Keywords:** geothermal heat pumps, UTES, history, development.

### ABSTRACT

The paper gives an account on the early steps towards use of heat pumps, and then focuses on the situation in Europe. Details are given on R&D-activities in Germany from the 1980s on, and on the related work in IEA-cooperation. Reports and findings from conferences of that time are highlighted, as well as steps towards guidelines and standards. Some examples of milestones in practical application are given. An assessment of the current status, both in technical development and market, and some cautious expectations for future development complete the picture.

Taking advantage of the steady temperature inside the earth goes back into prehistoric times, when caves or holes were used for storing food and for living, both in cold and hot climates. However, active use of this thermal energy reservoir required a tool for changing temperature, the heat pump to increase it, and the chiller (or a heat pump in reversed mode) for decreasing temperature. Practical application of the heat pump process was already done in the 19<sup>th</sup> century, with the example of the steam generation in Ebensee salt works in Austria.

The first claims on a heat pump extracting heat from the earth were made by Heinrich Zoelly in a Swiss patent of 1912. However, the first documented application in reality dates from 1945, in Indianapolis, USA, and in Europe the first groundwater heat pump is reported in 1950 in Thun, Switzerland. Information on a few more ground-source heat pumps in Europe is from the 1960s, and it took the two oil-price peaks in 1973 and 1980/81 to spark interest in heat pumps. R&D on geothermal heat pumps had a first boom in the 1950s in USA and Canada, and after the first oil price crisis in 1973, it started in Europe and Japan, and resumed in North America. Today, ground source heat pumps and underground thermal energy storage are an accepted part of sustainable solutions for providing heat or cold, and the number of ground source heat pumps in Europe alone rose to over 1.7 Mio in 2015 (Antics et al., 2016). Furthermore, universities, research institutes, and private companies all over Europe are active in shallow geothermal R&D today.

### 1. INTRODUCTION

Being interested in history since school times, the author would not need a justification for his expeditions into the heritage of shallow geothermal. However, the reason why to put some thoughts and accounts on paper for a larger audience should be explained shortly. Recent history of science and technology (and of society in general) has a pivotal break at the end of the 20<sup>th</sup> century: Up to then, information was contained and distributed in paper form, in books, journals, studies, letters... - just like all the many decades ago, basically since antique times. The development of the internet changed everything.

In the 1980s, it already became possible to research for literature and data in electronic databases. ‘On line’ was a true word then, e.g. with telephone handsets inserted into acoustic couplers and electronic signals crawling through telephone lines. The access to literature databases was costly, and usually required some training with the necessary search algorithms in order to retrieve something meaningful. A predecessor of the internet we know today was already up and running, but limited to the scientific world. From 1990 on, the structures were opened to commercial use – and the online-world began, slowly first, and then, quickly, with increasing momentum. More and more information became available, and search machines like Yahoo and later Google allowed for retrieval of information from the gigantic amount of data stored electronically. Today, finding really valuable information nevertheless can be like looking for a needle in a haystack, and quite often just straw is found.

Literature research by browsing through catalogue cabinets in libraries, or trying to get hold of the original papers cited in books and papers, is definitely a thing of the past. Most scientific journals, conferences, etc. meanwhile offer search through the internet. Hence the information printed on paper before the advent of the internet is hardly found today. And most of the reports and publications from the early development of shallow geothermal energy use are just that – words and graphs printed on paper. The author hopes to make some of the development of shallow geothermal available to those who did not experience that time in person, and to bring into perspective the status achieved today and the expectations for the future.

## 2. HISTORY

Temperature changes on the surface decrease inside the ground, and beneath a depth of about 10-20 m the earth has steady temperature throughout the year. This fact is used by animals since there is life on land, and since prehistoric times also by human beings, hiding in holes or caves to keep cool in hot climate, or warm in cold winters. In areas with suitable geology whole cities were dug into the rock. Areas with similar, well-suited volcanoclastic rocks in New Mexico in the USA, and in Cappadocia in Turkey, have resulted in astonishingly similar ‘cave cities’, where people and their food supply stay comfortable despite harsh outdoor climate. Old, rural houses and storage sheds in Iceland and Northern Scandinavia used to be partly underground, as still can be seen in places (figure 1). And even into the modern era deep cellars are used for food, wine, etc., and even to store ice harvested in winter for cooling in summer. Mechanical refrigeration has ended the natural ice business, but new, modern approaches to use of underground space have emerged.



**Figure 1: Storage shed partly underground in Emmaboda, Sweden, amid modern houses in 2007**

Scientific description of the decrease of temperature changes with depth has started in the late 17<sup>th</sup> century, when temperature readings were taken in the cellar of the Observatoire de Paris, and Antoine Lavoisier later installed a thermometer there. Buffon (1778:495) describes the steady temperature reading throughout the seasons. Two decades later the German Alexander von Humboldt visits the place during his studies in Paris. Humboldt (1799:82) states: ‘The average temperature which the observations done since 1680 revealed is 9.6 R’. This value is equal to 12 °C, and the seasonal temperature variations are recorded as maximum 0.03 R (0.04 °C).

In Scotland, ground temperature measurements were done since 1838 over many years on the grounds of the Royal Observatory in Edinburgh (figure 2). These data were used by both Thomson (1860) and Everett (1860) to empirically validate their formulas for the decrease of surface temperature variations towards depth and the retardation of phase. Thomson (1860) calculates that temperature variation is only 1/20 of the variation on the surface in 8.1 m depth, and 1/400 in 16.2 m depth.

The temperature in the shallow geothermal realm is also influenced by the geothermal heat flux and the

resulting geothermal gradient. With mines exploiting deeper and deeper resources, miners in the middle ages started to feel the geothermal heat. The first to attribute this to a hot interior of the earth and to give a cause (an internal fire) for it was Kircher (1665). He also mentioned a geothermal gradient, citing reports from miners in the region of Chemnitz, Germany.

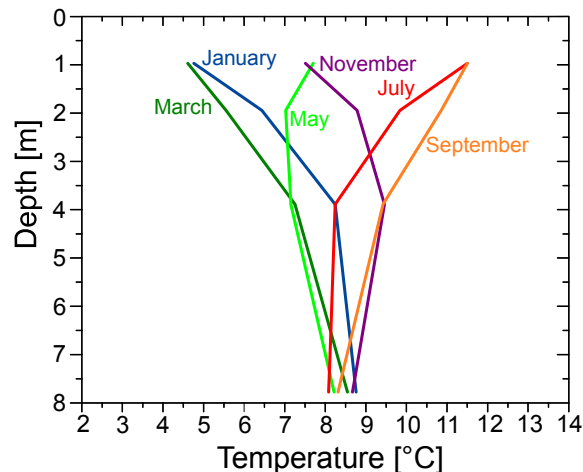

**Figure 2: Measurement of ground temperature at the Royal Edinburgh Observatory, average values 1838-1854, after data from Everett (1860)**

It took more than hundred years before another scientist started to put numbers to the geothermal gradient. Buffon (1778:495) first also cites account from miners from Eller, Germany: “à mesure que les mineurs descendent, ils recontrent une température d’air toujours plus chaude” (the deeper the miners descended, the higher the air temperature they encountered). He then lists numbers for the temperature increase towards depth, like the readings from Giromagny near Belfort (taken by de Gensanne) shown here in table 1.

**Table 1: Temperature increase with depth as given by Buffon (1778) for Giromagny; original values converted to modern units by the author**

Depth	Temperature
101 m	12,5 °C
206 m	13,1 °C
307 m	19,0 °C
432 m	22,7 °C

Cordier (1827) endeavoured on a collection of data on underground temperatures from various places, and concludes: ‘If some observations that seem to have to big uncertainty are discarded, the others prove in more or less obvious way that there is a temperature increase from the surface towards the interior of the earth; hence it is justified to concede such increase. [...] The differences between results that have been obtained in the same way are not only a result of lacking experience, but can also be attributed to a

certain irregularity of the distribution of the underground heat from one country to the other.' Cordier (1827) thus not only described the geothermal gradient, but also the basis for heat flow maps. For the site of the Observatoire de Paris he calculated an increase by 3.6 °C per 100 m.

Still the idea of a hot interior of the earth was not fully accepted in the early 19<sup>th</sup> century. The recording of underground temperatures was intended to prove or contradict that concept. Work bei Kupffer (1829), Reich (1834) and Bischof (1837) provides a wealth of data, showing geothermal gradients of 2-4 K per 100 m. Bischof (1837) seems to be the first to understand that also the thermal conductivity of the rocks

influences the value for temperature increase towards depth. Towards the end of the 19<sup>th</sup> century, Lebour (1882) can present 57 series of underground temperature data, mostly from France and England, and obtains geothermal gradients of 1.1-6.4 K per 100 m from these data. The highest gradients, of more than 5 K per 100 m, were found in mines in Cornwall.

The effects of seasonal variations of surface temperature, decrease of such variations into the ground, and the geothermal heat flow from below control the shallow geothermal systems. A typical temperature distribution resulting from the interplay of these factors is shown in figure 3. At the end of the 19<sup>th</sup> century, these factors were fairly well understood.

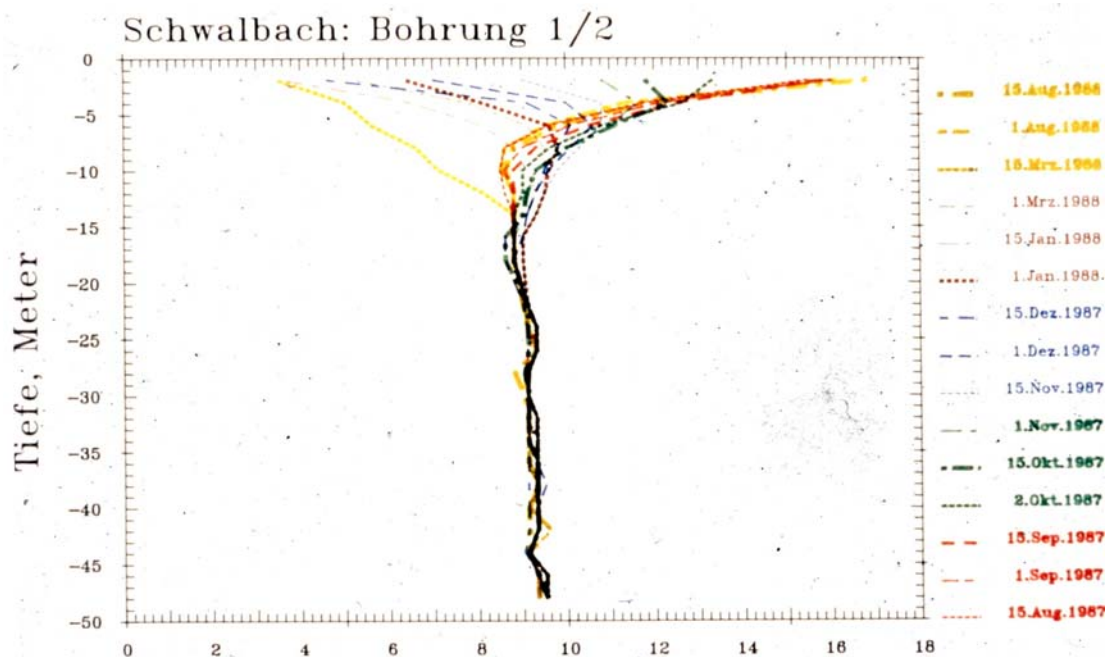

**Figure 3: Original plotter graph from 1987 showing the undisturbed temperature development along a borehole 50 m deep over one year, from August 1986 to August 1987, in the Schwalbach GSHP research station**

In order to actively use the shallow underground for energy production or storage, a tool is required for changing temperature, the heat pump to increase it, and the chiller (or a heat pump in reversed mode) for decreasing temperature. An early vision of such a machine with two cylinders in series is given by Thomson (1853), the processes is intended both for heating and cooling. In a note added to the article in 1881 Thomson writes that in the meantime, machines based in his principle were used for cooling, e.g. for transporting meat on ships, and continues: *“The method of heating air described in the article remains unrealized to this day”*.

Practical application of thermodynamic processes was developed in the second half of the 19<sup>th</sup> century, primarily for refrigeration (e.g. producing ice). Working fluids were water vapour, methyl ether, carbon dioxide, and ammonia.

Today it is generally accepted that the first practical application of the heat pump principle was made by

Peter von Rittinger in 1857, using vapour compression in a closed batch circuit to evaporate water and thus produce salt from concentrated brine in the Ebensee salt factory in Austria. He explained his idea in the words ‘Steam can generate mechanical work, but hardly any physicist will doubt the sentence expressed in the reversed sense, mechanical work can generate steam’ (Rittinger, 1855). The compressor was driven by water, a readily available resource in the area, and thus valuable firewood could be saved with the process. The heat pump reputedly had a thermal capacity of 14 kW (Zogg, 2008).

### 3. DEVELOPMENT IN THE 20<sup>TH</sup> CENTURY

#### 3.1 Development until the first oil price crisis 1973

It is well known that on 13<sup>th</sup> February 1912 a patent in which a ground-source heat pump is described was applied for by Heinrich Zoelly, of some fame in water and steam turbine design and with the development of steam turbine locomotives. The main claim in this



Swiss patent No. 59350, granted in 1919, was as follows (cited after Wirth, 1955; translation by the author):

„Heizverfahren, dadurch gekennzeichnet, dass man durch einen Elektromotor einen Kompressor treibt, welcher einen Wärmeträger in einem Kreisprozess fördert, dessen Verlauf gleichartig ist mit demjenigen, den der Kälte­träger durch die Tätigkeit einer Kompressionskältemaschine erfährt, wobei Mittel vorgesehen sind, um den Wärmeträger aus dem Erdboden Wärme aufnehmen zu lassen.“

(Heating process, in which an electric motor drives a compressor which forwards a heat carrier medium in a process cycle, the principle of which is equivalent to the process cycle a refrigerant experiences in the operation of a compression cooling machine, and where facilities are foreseen to allow the heat carrier medium to take in heat from the ground.)

For house heating, heat pumps were first applied in the 1930s, for instance 1938 in Zurich, Switzerland, where the town hall was heated by a heat pump using river water as heat source, with entering water temperatures as low as 1.2 °C in winter (Egli, 1944) – not a geothermal system by definition, but ‘hydrothermal’ as to the EU Directive 2009/28/EU on renewable energies. The heat pump supplied up to 100 kW heat and achieved an annual COP of almost 2.2 (including river water pump) in 1938/39 (Zogg, 2008). More heat pumps were installed for other buildings in Zürich, due to the restriction on coal supply from abroad during the Second World War: for an indoor swimming pool in 1941, for supply to the district heating net in 1942, and for two buildings of the city administration in 1943/44. The heat pump in the town hall had a very long service life of 63 years, with the compressor replaced in 1964, before being retired in 2001. It was still operational for heritage purposes in 2008 (Zogg, 2008).

Directly after the war, only few heat pumps were installed in Europe. Zogg (2008) reports a groundwater heat pump (thus truly geothermal by definition) around 1950 in Thun, Switzerland. A heating capacity of 440 kW was achieved, and the low supply temperature to the heating system of 40 °C, unusual for that time, allowed for an excellent annual COP of 4.5.

Across the Atlantic, the years between 1945 and the early 1950s were a heyday of heat pump development. The first true ground-source heat pump was installed in Indianapolis in 1945 (Crandall, 1946), a direct-expansion system with horizontal pipes in the ground (figure 4). Development mushroomed, and also theoretical work for ground loop design methods started. The largest ground-source heat pump of that time was constructed 1948 as a groundwater heat pump for the Equitable Building, in Portland OR (ASME, 1980). More details on the period are given in Sanner (1992) and Sanner (2005). In Europe this development was mainly ignored in the difficult post-war time. The years of low fuel prices in the 1950s and 60s brought

the development in America to a halt, prevented interest in heat pumps in Europe, and resulted in the retirement of many existing ground source heat pumps.

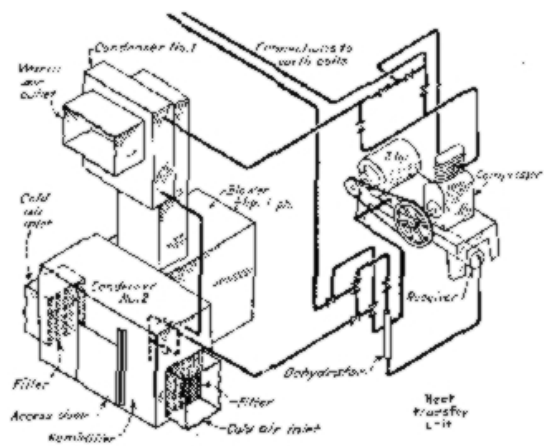

**Figure 4: Schematic of the direct-expansion ground source heat pump installed in the Webber house in Indianapolis in 1945 (from Crandall, 1946)**

### 3.2 Development during the first and second oil price crisis, 1973-1985

In October 1973 the OPEC decided on a reduction of oil supply to the Western countries as retribution to the West supporting Israel in the Yom-Kippur-war. Oil prices soared, and alternatives were sought. It is much easier to replace oil in stationary applications like heating than in transport, and thus heat pumps became popular as heating option. It took some time after 1973 to develop the necessary equipment, and so the heat pumps were available quite in time for the second oil price crisis in 1980/81, caused by the revolution in Iran and the subsequent Iran-Iraq-war. Heat Pump sales and oil price development in Germany can be seen in figure 5.

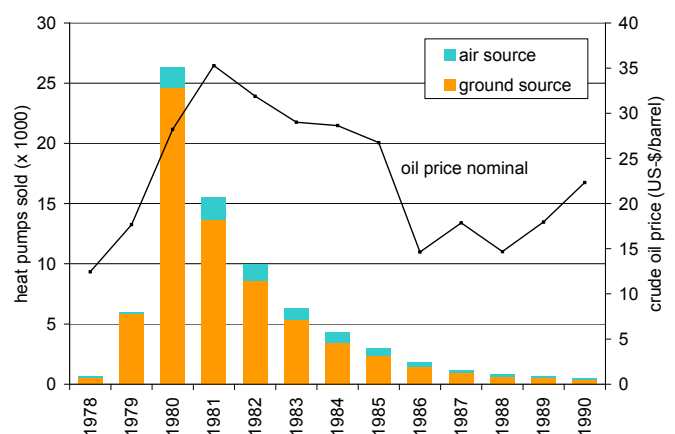

**Figure 5: Development of heat pump sales and crude oil price in Germany 1978-1990 (after data from BWP)**

The development had started already before the oil price shock. A first ground-source heat pump in Germany, using horizontal loops, became operational

already in 1969 (Waterkotte, 1972). Groundwater wells as heat source for heat pumps followed soon after (Drafz, 1972). The number of publications on the different types shows clearly that BHE followed several years later (figure 6). This evaluation is based on my personal database, from which only European papers were considered here; some key publications are listed in table 2. The shape of the graph clearly reflects the heat pump boom around 1980, as seen in figure 5. It is also interesting to see from table 2 that environmental aspects were part of the spectrum of publications almost from the beginning (e.g. Müller, 1978; Halldin et al., 1979), as well as permitting issues (Dybowski, 1978)

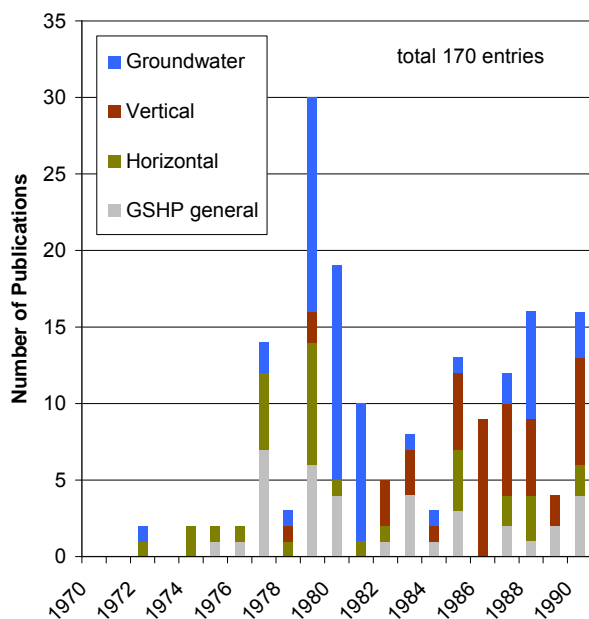
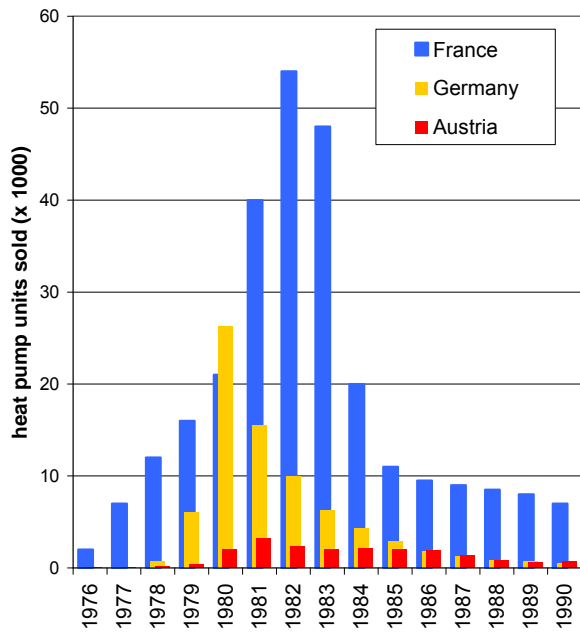

**Figure 6: Number of publications on GSHP with different ground-coupling technology in the years 1970-1990**

Thus for the second oil price crises, heat pumps were available from factories large and small, mainly in Austria, France, Germany, Sweden, Switzerland, but also elsewhere. In Germany, most were coupled to horizontal loops or groundwater wells, some used air as heat source. Many heat pumps were installed in bivalent systems as addition to existing boilers, causing a plethora of problems in control, hydraulics, and temperature levels. The lack of experience, quality, knowledge of the installers, etc. ruined the reputation of heat pumps in Germany around 1980, and the sales numbers dropped before the oil price did (cf. figure 5). A similar development happened in France, the peak being slightly later, and in Austria, where the absolute numbers were lower and the decrease less drastic (figure 7). Smaller companies simply disappeared, and the large boiler manufacturers, having started also on heat pumps, closed their respective departments. Only a few companies with good knowledge and experience, and sufficient persistence, continued and became the core of the positive evolution after 1990.

**Table 2: Examples of early shallow geothermal publications in Europe, sorted into application fields (full bibliographical data in the references)**

Early publications on GSHP	
Groundwater	Drafz (1972), Jänisch (1978), Hakenbeck (1979), Reimann (1979), Schnell (1979), Wolf (1979), Jäckli (1980), Grouvel and Boissavy (1988)
Horizontal	Waterkotte (1972), Sowa (1974), Rouvel (1975), Möller (1976), Schär (1977), Eickenhorst (1977), Ginschel (1977), Von Cube (1977), Specht (1978)
BHE	Goulburn and Fearon (1978), Mahlbacher (1979), Rosenblad (1979), Agthoven and Wiskie (1982), Drafz (1982), Schwanner and Hopkirk (1982), Bouma and Koppenol (1983), Goulburn and Fearon (1983), Hopkirk and Gilby (1985), Katona and Brandner (1985), Mogensen (1985), Tollin (1985), Katona (1986), Sanner et al. (1986), Schaumann and Hoffmann (1986), Tollin and Åbyhammar (1986), Rybach (1987), Sanner (1987)
Undefined / other	Paul (1976), Neiss and Winter (1977), Bäckström (1979), Fordsmann (1979), Mogensen (1979), Rouvé et al. (1980), Balke (1981)
Early publications on UTES	
ATES	Kley and Nieskens (1975), Matthey (1977), Werner and Kley (1977), Andersson et al. (1983), Hansen et al. (1984), Boileau et al. (1985), Eriksson (1985), Hadorn et al. (1985), Hydén (1985), Iris et al. (1985), Qvale (1985), Fisch and Giebe (1986)
BTES	Lindblom (1980), Bruck et al. (1981), Schulz (1983), Aranovitch et al. (1985), Hultmark (1985), Lazzarin and Schibuola (1985), Matthey and Pillonel (1985), Nordell (1985), Reuss and Schulz (1985), Wijsman (1985), Wilén (1985)
Undefined / other	Brun (1964), Delisle (1977), Andersson (1985)
Early publications on mathematic and calculation	
Neiss and Winter (1976), Matthey (1979), Runesson et al. (1979), Claesson and Johansson (1980), Mull and Schulz (1982), Hellström (1983), Mogensen (1983), Pelka (1983), Claesson et al. (1985), Kangas et al. (1985), Pelka (1985), Sauty and Ausseur (1985), Eskilson (1987), Claesson and Eskilson (1988)	
Other early publications (e.g. environment, drilling)	
Müller (1978), Halldin et al. (1979), Dybowski, (1978), Andersson (1981), Troedsson (1983), Svensson (1983), Schunesson (1985), Nelson (1987)	



**Figure 7: Development of heat pump sales in France, Germany and Austria 1976-1990; heat pump water heaters excluded (after data from AFPAC, BWP and EHPA)**

Borehole heat exchangers had their start just during the boom. First experiments are reported from UK, Netherlands and Sweden. In Germany, first BHE were installed in the late 1970s, but not documented in publications. The first (West-)German document on regulation of GSHP (LAWA, 1980), edited by the joint working group on water of the relevant state authorities, dealt mainly with groundwater heat pumps, but included also a few pages on the “new technology” of BHE, showing a coaxial BHE as example (figure 8).

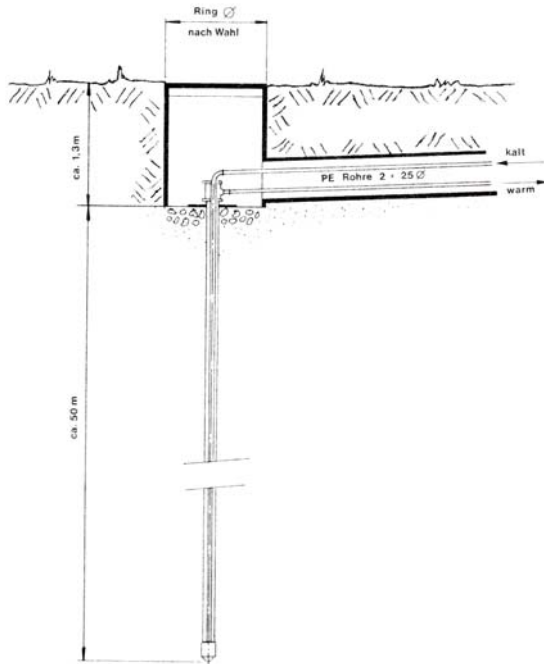

**Figure 8: Example of coaxial BHE from LAWA (1980)**

A German company brochure (WTA, 1981) shows photos of drilling and installation for a coaxial BHE, made from corrugated stainless steel for the outer pipe, and a rubber hose for the inner pipe. The first Swiss experiments with BHE also started around the same time, with the first modern BHE made of PE-pipes installed in 1980 (Rohner, 1991); Austria followed soon after.

### 3.3 Development after the “boom and crash”

As a result of the market disaster, more cautious approaches were used in Germany. In Sweden, where no sales crash of the type in France and Germany happened, proper R&D had accompanied the development, and now also other countries followed that example. Numerous conferences and workshops allowed for exchange of experience and new discoveries; table 3 gives an account of this activity. For the German speaking countries in particular the Symposia in Rauschholzhhausen, the meeting centre of Giessen University, had a pivotal role in bringing research and practice together (figure 9).



**Figure 9: GSHP-events in Schloss Rauschholzhhausen; participants of a workshop on direct expansion GSHP (not listed in table 3) in front of the main mansion in 1987 (top) and the scientific committee of the first Symposium on GSHP in 1991 (bottom), from left: Axel Lehmann, Volkmar Lottner, Gerhard Faninger, Burkhard Sanner, Hans Ulrich Schärer and Klaus Knoblich**

**Table 3: Conferences and workshops on shallow geothermal topics in Europe, or with high influence for Europe, in the last decades of the 20<sup>th</sup> century**

Year	Title	Venue	Date
International events in Europe			
1979	Nordic Symposium of Earth Heat Pump Systems	Göteborg, Sweden	15.-16. October 1979
1982	1 <sup>st</sup> Workshop on Solar Assisted Heat Pumps with Ground Coupled Storage	Ispira, Italy	
1983	International Conference on Subsurface Heat Storage	Stockholm, Sweden	6.-8. June 1983
1984	1 <sup>st</sup> IEA Heat Pump Conference: Current Situation and Future Prospects	Graz, Austria	22.-25. Mai 1984
1985	2 <sup>nd</sup> Workshop on Solar Assisted Heat Pumps with Ground Coupled Storage	Vienna, Austria	8.-10. Mai 1985
1987	Nordic workshop on computational methods of seasonal storage solar heating systems	Otaniemi, Finland	12.-13. June 1987
1988	4 <sup>th</sup> International Conference on Energy Storage for Building Heating and Cooling, JIGASTOCK 88	Versailles, France	18.-21. October 1988
1989	3 <sup>rd</sup> Workshop on Solar Assisted Heat Pumps with Ground Coupled Storage	Göteborg, Sweden	13.-14. January 1989
1990	Workshop on Thermal Energy Storage in Duct Systems	Freising, Germany	19.-20. June 1990
1991	5 <sup>th</sup> International Conference on Energy Storage for Building Heating and Cooling, THERMASTOCK 91	Scheveningen, Netherlands	13.-16. May 1991
1993	4 <sup>th</sup> IEA Heat Pump Conference: Heat Pumps for Energy Efficiency and Environmental Progress	Maastricht, Netherlands	26.-29. April 1993
1994	6 <sup>th</sup> International Conference on Energy Storage for Building Heating and Cooling, CALORSTOCK 95	Espoo/Helsinki, Finland	22.-25. August 1994
1995	World Geothermal Conference WGC 1995	Florence, Italy	21.-27. May 1995
National events in Europe (Germany and Switzerland only)			
1979	Statusseminar Wärmepumpen und Grundwasserschutz	Berlin, Germany	19.-20. November 1979
1980	La pompe à chaleur et son utilisation en Suisse	Lausanne, Switzerland	5.-6. May 1980
1986	Symposium Erdwärmepumpen und Erdwärmespeicher	Giessen, Germany	23.-24. June 1986
1991	Symposium Erdgekoppelte Wärmepumpen	Rauischholzhausen, Germany	7.-9. October 1991
1992	3. Informationstagung SVG, Erdwärmesonden / Nutzung der Oberen Meeresmolasse	Zürich, Switzerland	25. September 1992
	2. Geothermische Fachtagung GtV: Technologie, Ökologie, Ökonomie	Erding, Germany	12.-15. October 1992
1993	4. Informationstagung der SVG, Energiepfähle	St. Gallen, Switzerland	6. May 1993
1994	5. Informationstagung der SVG, Wärmepumpen und Fernwärme	Riehen, Switzerland	15. April 1994
	3. Geothermische Fachtagung GtV: Geothermische Energie, Nutzung, Erfahrung, Perspektive	Schwerin, Germany	5.-7. October 1994
	2. Symposium Erdgekoppelte Wärmepumpen	Rauischholzhausen, Germany	17.-19. October 1994
	VDI-Tagung Energiespeicher für Strom, Wärme und Kälte	Leipzig, Germany	6.-7. December 1994
1995	6. Fachtagung der SVG, Umwelt- und Gewässerschutz bei Erdwärmesonden	Delémont, Switzerland	28. April 1995
	VDI-Tagung Wärmepumpen: Energieeinsparung und Umweltschutz	Kassel, Germany	16. May 1995
1996	4. Geothermische Fachtagung GtV / 7. Fachtagung SVG: Geothermie – Energie der Zukunft	Konstanz, Germany	18.-20. September 1996
1997	3. Symposium Erdgekoppelte Wärmepumpen	Rauischholzhausen, Germany	20.-22. November 1997
1998	5. Geothermische Fachtagung GtV: Forschung, Entwicklung, Markt	Straubing, Germany	12.-15. May 1998



Table 3 continued

Year	Title	Venue	Date
Conferences and workshops outside Europe:			
1985	3 <sup>rd</sup> International Conference on Energy Storage for Building Heating and Cooling, ENERSTOCK 85 <sup>1</sup>	Toronto, Canada	22.-26. September 1985
1986	IEA Workshop on Ground Source Heat Pumps <sup>2</sup>	Albany NY, USA	29. Oct. - 1. Nov. 1986
1987	2 <sup>nd</sup> IEA Heat Pump Conference: Prospects in Heat Pump Technology & Marketing <sup>3</sup>	Orlando FL, USA	28.-30. April 1987
1990	3 <sup>rd</sup> IEA Heat Pump Conference: Solving Energy and Environmental Challenges <sup>4</sup>	Tokyo, Japan	12.-15. March 1990
1991	IEA Workshop on Ground Source Heat Pumps, Advances towards cost reduction <sup>5</sup>	Montreal, Canada	12.-13. August 1991
1996	5 <sup>th</sup> IEA Heat Pump Conference: Solving Energy and Environmental Challenges <sup>6</sup>	Toronto, Canada	22.-26. September, 1996
1997	7 <sup>th</sup> International Conference on Energy Storage for Building Heating and Cooling, MEGASTOCK 97 <sup>7</sup>	Sapporo, Japan	18.-21. June 1997

<sup>1</sup> Proceedings: Public Works Canada, Ottawa (1985)  
<sup>2</sup> Proceedings: Calm, J.M. (ed.), IEA HPC-WR-2, Karlsruhe (1987)  
<sup>3</sup> Proceedings: Zimmermann, K.H. (ed.), Lewis Publishers Inc., Chelsea MI (1987)  
<sup>4</sup> Proceedings: Saito, T. and Igarashi, Y. (eds.), Pergamon Press, Oxford (1990)  
<sup>5</sup> Proceedings: IEA-HPC-WR-8, Sittard (1991)  
<sup>6</sup> Proceedings: National Research Council Canada, Ottawa (1996)  
<sup>7</sup> Proceedings: Ochifuji, K. and Nagano, K. (eds.), Hokkaido University, Sapporo (1997)

On the R&D-side, more financial support was given for GSHP development in the countries where a heat pump market had started. In 1985 a private company, Helmut Hund GmbH, started on a project for a full-scale research station for BHE in cooperation with the University of Giessen and an installation company, Geotherm GmbH. The work was supported by the Federal ministry of research and technology (BMFT), and resulted in the Schwalbach GSHP research station shown in figure 10 (Sanner, 1986). In 1986 this project became part of Annex 8 of the IEA Heat Pump Programme.



**Figure 10: Schwalbach GSHP-research station on a very cold day in January 1988**

In Annex 8 ‘Advanced In-Ground Heat Exchange Technologies’ institutions from Canada (NRC Ottawa), Germany (Giessen Univ. / Hund), Switzerland (ETH / Polydynamics) and USA (Oak Ridge NL) worked together. Each had either a test site for BHE, or used measurements from commercial plants with additional sensing, like in Elgg ZH in Switzerland (Eugster, 1991).

Schwalbach GSHP research station was operated from 1985-89, the main results are summarised in Knoblich et al. (1993). The station consisted of a shack with heat pump and two fan-coil units towards the ambient air (figure 12), coupled to a borehole heat exchanger (BHE) of 50 m depth (Z in figure 11, 13 and 14). That BHE was surrounded by a number of boreholes with temperature sensor cables to the same depth, and two wells for hydrogeological investigation (figure 11).

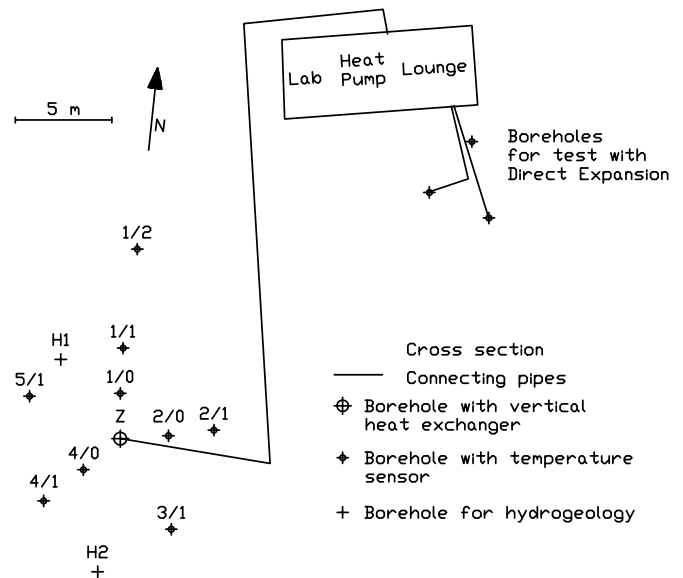

**Figure 11: Schwalbach GSHP-research station, final plan of the installation as of 1988**

The pattern of the BHE and boreholes with sensors allowed for visualising the temperature distribution during heat extraction and recovery; an example is given in figure 13.



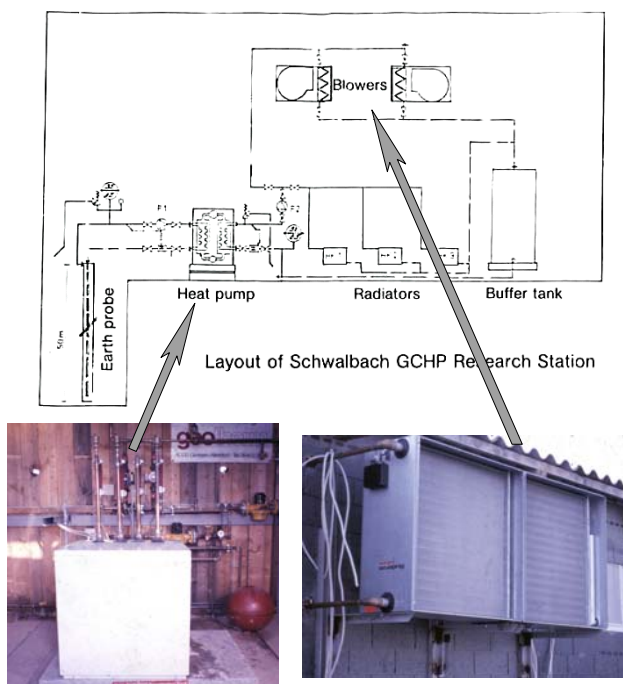

**Figure 12: Schwalbach GSHP-research station, schematic (from Sanner, 1987) with photos of components**

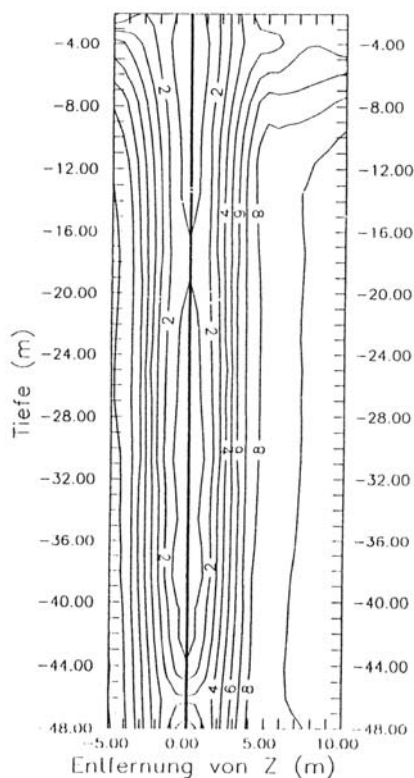

**Figure 13: Example of temperature distribution around BHE in Schwalbach GSHP-research station on 1.4.1987**

The system setup allowed for extracting heat from the ground, independent of any building heating requirement – a kind of ‘immobile TRT rig’. This feature was used e.g. to investigate the heat transport in the ground by running tests with relative stable temperature in the BHE over various time periods, up

to one month (figure 14). A Finite-Difference-model TRADIKON-3D for numerical simulation of the heat transport was developed at Giessen university and validated using the data from Schwalbach (Brehm, 1980); in particular the sophisticated freezing algorithms included in TRADIKON-3D could be checked against real data like those shown in figure 15. The IEA-cooperation strongly supported the work, with the possibility to compare the freezing effects with experiments at NRC Ottawa and the numerical simulation with the experiences from Oak Ridge NL in USA.

Similar Research installations were built and operated in the following years in Europe, including:

- HTL Burgdorf, Switzerland (around 1995)
- EDF Lab les Renardières, France (around 2000)
- BRGM Orléans, France (around 2000, still operational)

and others.

### 3.4 Design methods for BHE installations

In the beginning, the design of GSHP installations was done mainly by rules of thumb (usually 50 W/m in Germany and 55 W/m in Switzerland). Mathematical descriptions had already been developed during the first GSHP era in the USA around 1950, and furthermore in France, Germany and Sweden at the end of the 1970s (cf. table 2); however, these methods could not be used by most practitioners. A group of Physicists and Mathematicians at Lund University started in the 1980s to create accurate descriptions of the heat transport (Claesson et al, 1985), and later to simplify the calculations in the form of small computer programs. Together with the development of the PC, these methods could be easily applied and changed the design practice, at least for larger projects. For the single family house, the rules of thumb somehow survive until today, albeit guidelines in most countries meanwhile offer much better design options. In 1992 the mathematical excellence at Lund University and the practical experience at Giessen University were combined to create the first version of the program EED (Hellström and Sanner, 1994), which helped numerous BHE projects to a correct sizing.

The development of a method to determine the thermal conductivity of the underground, the TRT, also took place during the 1990s. The first mobile TRT in Europe was done in Sweden in 1995, followed by tests in the Netherlands, and in Germany in 1999. An excellent and very comprehensive account on the history of TRT, dealing in particular with the theoretical concepts and evaluation methods, is given in Spitler and Gehlin (2015).

### 3.5 Market and guidelines for GSHP

The 1990s were also the time when work on guidelines for shallow geothermal energy started, first with AWP T1 in Switzerland and then with VDI 4640 in Germany, the first draft of which was published in 1998. In the absence of signals from the oil price front, market development (figure 16) was mainly due

to financial support programs (e.g. by electric utilities like RWE, or from the Federal ministry of economy since 1995). The experiences from R&D, design knowledge and eventually guidelines helped to secure that growth and to re-build customer confidence lost in 1980. The downward trend could be stopped and

reversed, starting a steady increase of GSHP sales in Germany well into the first years of the 21<sup>st</sup> century. Information campaigns helped also, and in Switzerland a working GSHP was even installed in a popular museum of natural history in St. Gallen (Sanner, 1994) (figure 17).

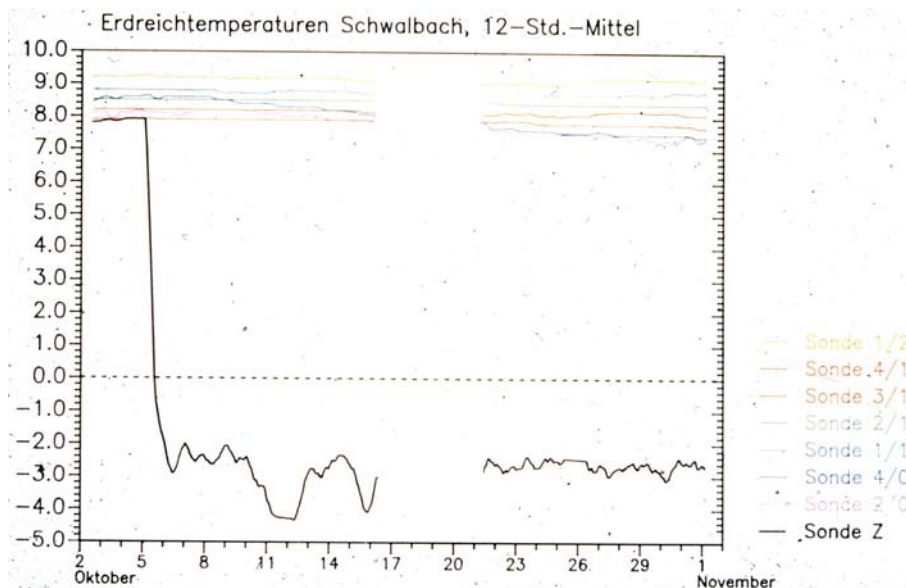

**Figure 14: Original plotter graph from 1986 showing the temperature development in the BHE (“Sonde Z”) and the surrounding observation boreholes (cf. figure 11) during a long-term extraction test with target temperature -3 °C in October 1986 in Schwalbach GSHP research station**

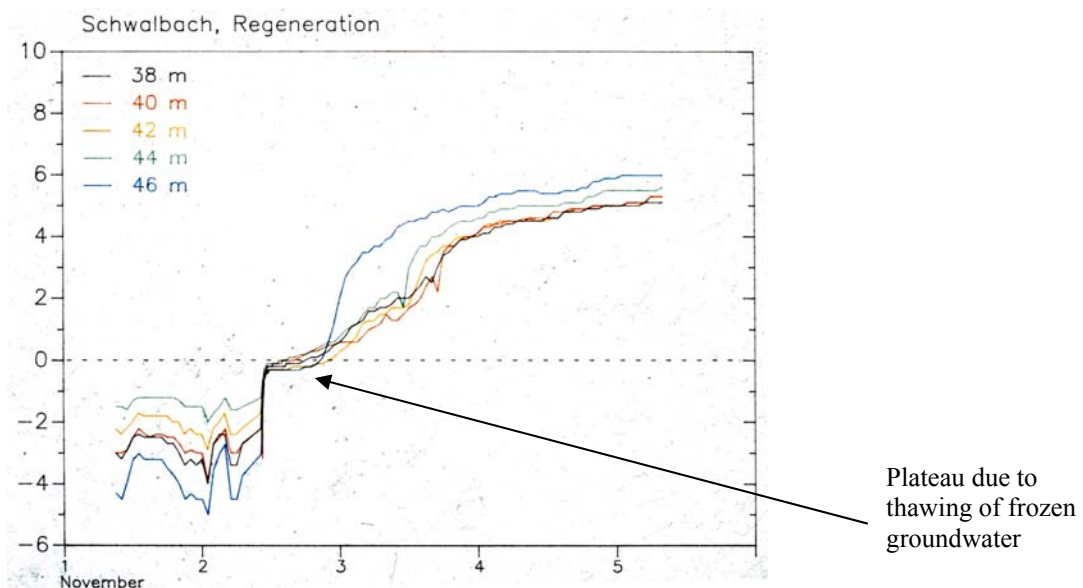

**Figure 15: Original plotter graph from 1986 showing the temperature development at different depth in the BHE in Schwalbach GSHP research station in the beginning of November 1986, after a long-term extraction test with target temperature -3 °C in October 1986 (cf. figure 14)**

### 3.6 A glimpse on UTES

Early industrial use of underground thermal energy storage was done since about 1960 in aquifers near Shanghai, China (Sun et al., 1991). First ideas to use ATES for storing solar energy were described by Brun (1964), and a Russian team proposed sandy gravel to store solar heat (Rabbimov et al., 1971). ATES for storage of waste heat from power plants was consid-

ered in the USA by Kazmann (1971) and Meyer and Todd (1973). In Europe, experiments and test plants for ATES started in the 1970s, and on BTES a few years later. The installations were intended for seasonal storage, and the heat sources investigated comprised both solar heat and waste heat. Storage of cold from ambient air in winter for cooling purposes was considered only towards the end of the 1980s.

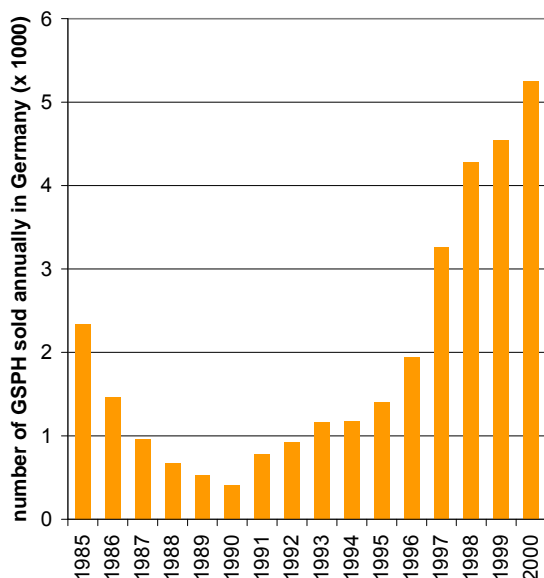

Figure 16: GSHP sales development in Germany 1985-2000 (after data from BWP)



Figure 17: GSHP in the museum of natural history in St. Gallen, Switzerland (photo from 1993)

With solar heat as source for UTES, R&D on the underground was also done within the solar energy sector, considering mainly two fields:

- Central Solar Heating Plants with Seasonal Storage (CSHPSS), referring to large central plants and local district heating
- Solar Assisted Heat Pumps with Ground Coupled Storage (SAHPGS), resulting in three dedicated events in 1982, 1985 and 1989 (cf. table 3)

All types of storage were addressed, like water tanks, pits, phase change materials (PCM), and UTES. Solar heat storage was included in relevant cooperation programs of the IEA, in Implementing Agreements on solar energy as well as in that on energy storage. SAHPGS was in particular supported on the European level, with JRC Ispra involved in organising the workshops mentioned, and in carrying out own R&D.

The distribution of publications on UTES in the 1980s into the different storage options is shown in figure 18. ATES and BTES are fairly well balanced. The main events in 1985 (Enerstock in Toronto, Canada)

and 1988 (Jigastock in Versailles, France) brought about the majority of publications.

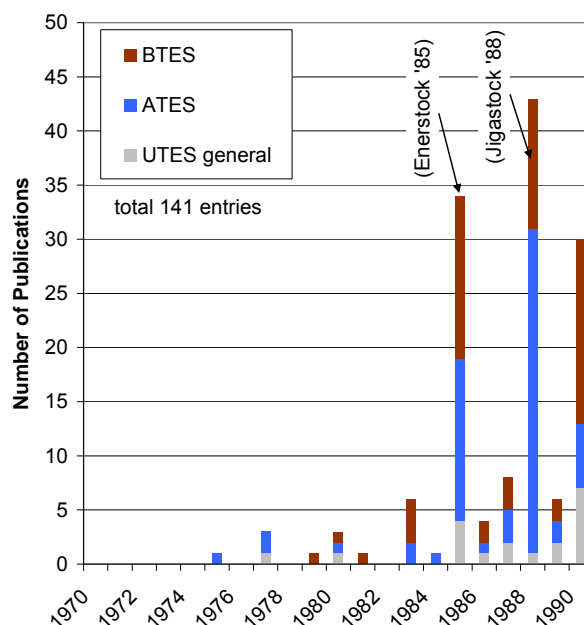

Figure 18: Number of publications on UTES with distinction of aquifer and borehole storage in the years 1970-1990

Within the IEA energy storage programme, Annex 7 (1992-95) dealt with seasonal cold storage, Annex 8 (1996-98) with implementing of UTES systems, and Annex 12 (1997-2003) with high temperature UTES (considered to exceed storage temperatures of 50 °C). The development of UTES in general, and the state of the art in the beginning of the 1990s, is summarised in Bakema et al. (1995). For the field of high temperature UTES, an account of the different projects and experiences since the beginnings in the 1970s is given in Sanner (1999).

#### 4. THE MARKET TODAY

The German GSHP market since the 1970s (figure 19) elucidates nicely some factors influencing the sales numbers, like events on the world markets, dedicated R&D, standards and incentives. The market in Germany developed quickly in the first years of the new Millennium and had another peak around 2006-2008. One reason was the insecurity in supply of natural gas from Russia, which had replaced fuel oil in the majority of houses in Germany. Alas, since that time the GSHP sales numbers are decreasing, while the share of air-source heat pumps is growing (figure 20). In 2015, for the first time less than 30 % of new heat pumps in Germany used a geothermal source! A similar, but slower trend can be seen for Switzerland, still showing approximately 36 % of ground source in the heat pump market (figure 20). Even more negative developments are reported from France. The situation throughout Europe is quite diverse, with some countries showing huge numbers of installations, and others with about the same population, but almost no GSHP (figure 21).

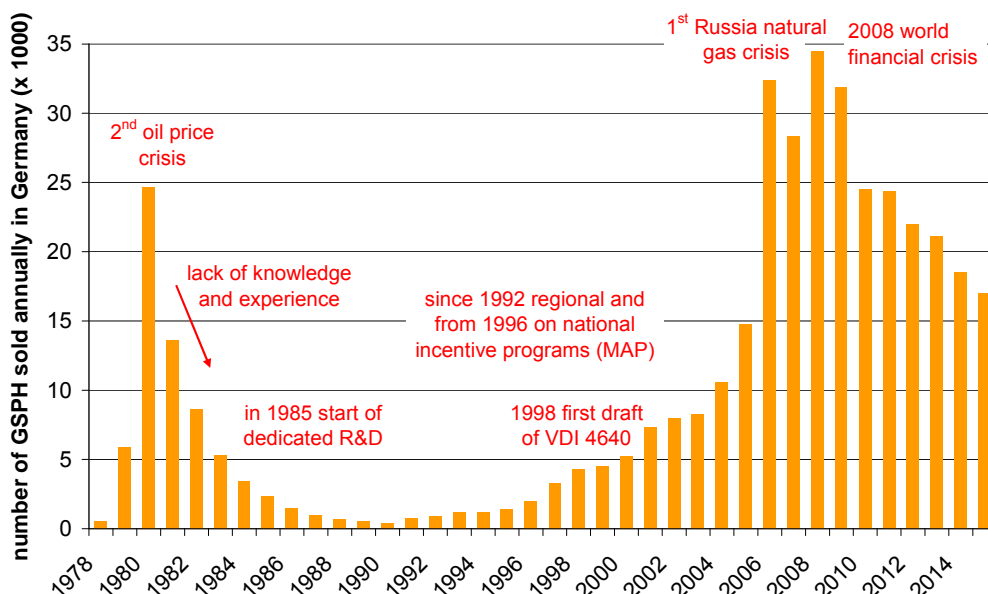

Figure 19: GSHP sales in Germany 1978-2015 and influencing events (sales numbers after data from BWP)

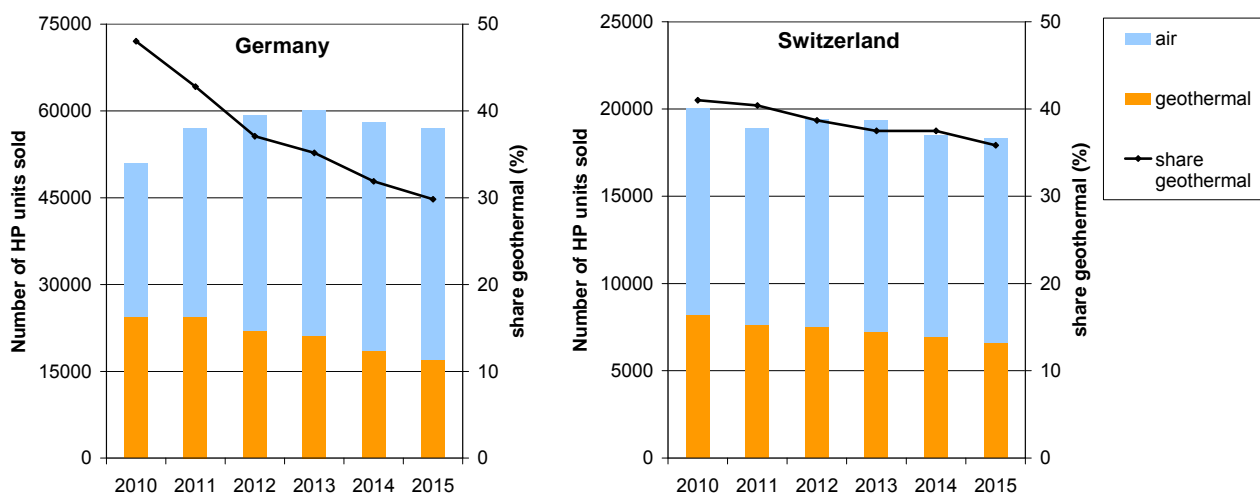

Figure 20: Heat pump sales 2010-2015 in Germany and Switzerland, and share of geothermal in total, after data from BWP and FWS

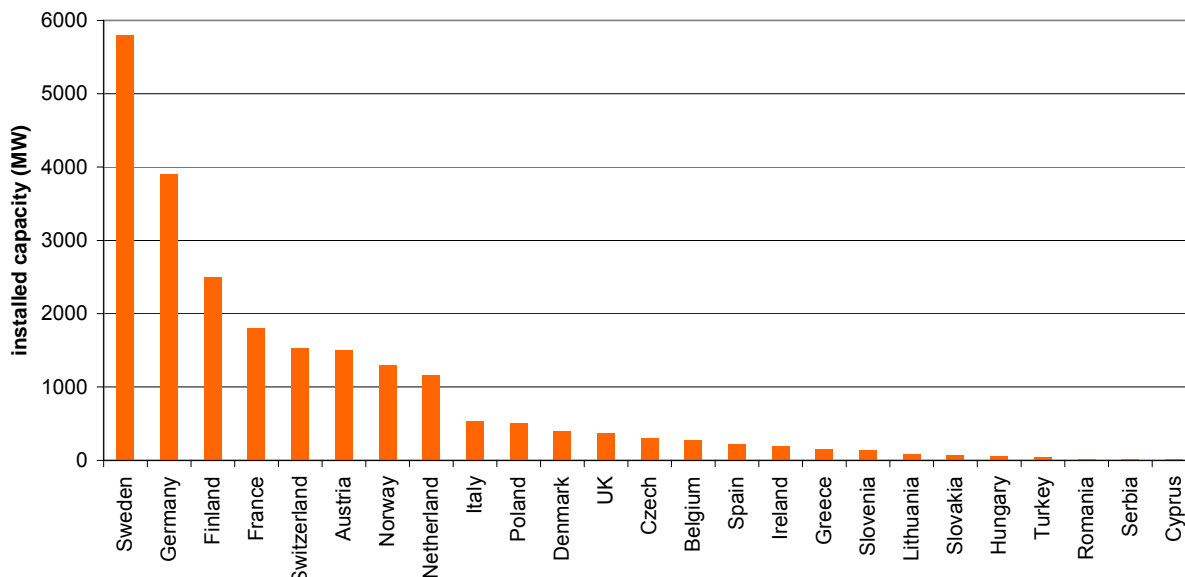

Figure 21: Total installed capacity in geothermal heat pumps in 2015 in Europe, after Antics et al. (2016)



In countries with substantial market development since many years (e.g. Sweden) already a replacement market has developed, as heat pumps achieve the end of their service life while the ground-coupling installations are far from worn out. If this ‘re-powering’ is done using new, more efficient heat pumps, it also requires thorough checks to make sure the old ground installation is capable to deliver the required heat (or inject the heat from cooling); this is often the case in combination with building refurbishment (e.g. better insulation), leading to reduced heat demand.

A specific challenge for the GSHP market of today is the low percentage of new construction. This requires addressing the existing building stock, a sector where geothermal installations are not easy to deploy. In Switzerland, a country with notoriously low new construction (“Switzerland is built up already”), an impressive share of >30 % of all drilling is done for existing buildings (figure 22), while the overall amount of BHE installation is rather stable since 2011 at approximately 2500 km of new BHE each year.

In the 21<sup>st</sup> century the development of GSHP continued steadily, and is well documented in material available online. Environmental aspects, work quality and permitting processes became more important, and in Switzerland, the country with the highest density of BHE world-wide, discussion even started about possible over-using the underground thermally.

**5. WHAT MIGHT BE ACHIEVED IN FUTURE?**

A basic fact not to be forgotten is that we are under the control of geology and climate – we cannot change the rock or soil outside the borehole, nor the overall temperature field. For BHE this means that optimisation by engineering is confined to the size of the borehole, and what we put inside. This is valid analogously for horizontal loops, energy piles etc. For BHE the parameter of ‘Borehole Thermal Resistance’ was introduced, combining all the effects from the rock outside the borehole into the fluid in the pipes (cf Eskilson, 1987). No borehole thermal resistance, i.e.  $r_b = 0 \text{ K}/(\text{W}\cdot\text{m})$ , would mean instantaneous transfer of

heat from the rock into the fluid and vice versa. Hence  $r_b$  can be used as a parameter to describe the quality of a BHE design, as influenced by geometry, pipe material, grouting, flow volumes, surfaces etc.

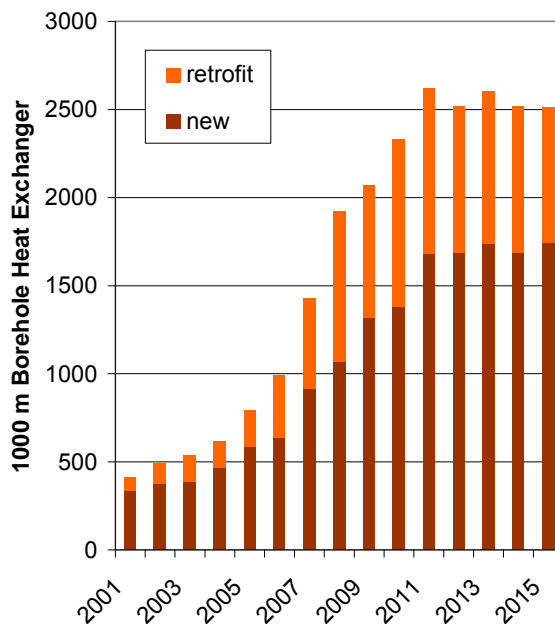

**Figure 22: Annual BHE drilling in Switzerland for new and existing buildings (in km of BHE), after data from FWS**

Because the ‘specific heat extraction rate’ of a BHE has no meaning without clearly defined boundary conditions, the ‘Hellström-Efficiency’ was introduced to allow comparison of BHE installations. It is defined as the ratio of heat extraction (under sustainable conditions) possible in a given, real installation to a heat extraction calculated under the assumption of  $r_b = 0 \text{ K}/(\text{W}\cdot\text{m})$  (Mands et al., 2008). An example of Hellström-Efficiency for a GSHP with 10 kW and rock with thermal conductivity  $\lambda = 2.5 \text{ W}/(\text{m}\cdot\text{K})$  is shown in figure 23, indicating the values achievable by some standard and some theoretical BHE designs.

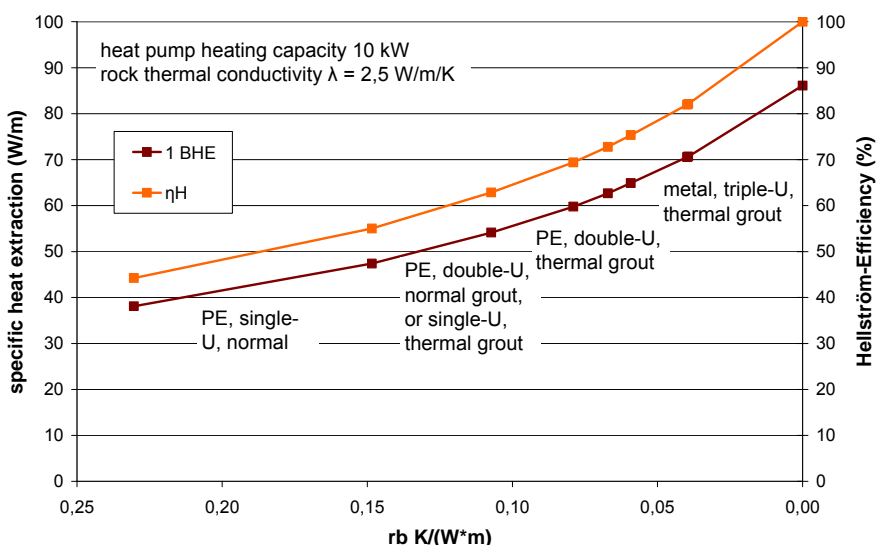

**Figure 23: Example of specific heat extraction rate and Hellström-Efficiency**

While specific heat extraction rate and  $r_b$  may vary according to the rock type, BHE design, size of the project (number of BHE), load profiles, etc., the Hellström-Efficiency  $\eta_H$  always shows how close a given installation is to the theoretical optimum. Any claims for heat extraction rates that would result in  $\eta_H$  of 100 % or more can be dismissed as physically impossible. New designs and materials might help to move closer to the optimum in routine installations, but not beyond.

The main Key Performance Indicators and Objectives for Ground Source Heat Pumps are:

- SG1. A Seasonal Performance Factor in the order of 5 for 2020.
- SG2. A Hellström-efficiency (a measure of the impact of borehole thermal resistance) of about 80% in 2020.
- SG3. A further decrease in energy input and reduced costs for operating the geothermal heat pump system.



<http://www.rhc-platform.org/publications/>

**Figure 24: Key Performance Indicators as in the Common Roadmap of the RHC-ETIP from June 2014 (for download from the website indicated)**

## 6. SOME FINAL THOUGHTS

Looking back at about 40 years of well-documented development in Europe, and more than a century of ideas and proposals, the status achieved today is characterised by sound knowledge and good design (albeit some shortcomings in practical execution cannot be overlooked). Often a certain feeling of déjà-vu goes with seeing new developments praised, as two examples might show. One is the use of BHE for direct cooling, the other the screw-type BHE.

Using the ground directly for cooling was already studied in the 1930s, and a patent was granted on 20<sup>th</sup> November 1934 under No. 1,981,730 to E.F. Hawkins of Evansville IN by the US Patents Office. It concerned a kind of BHE some 10-30 feet long (3-10 m), using the cold temperatures in the underground to cool the drinking water supplied to houses (figure 25). No heat pump was used, just the natural temperatures should do the job. Already the first GSHP in USA in 1945 was equipped for heating and cooling, however, with the heat pump running as chiller in cooling mode. Direct space cooling using BHE was the topic of a Swiss patent filed by Karl Hess in 1986 and granted on 15.9.1989 as CH 671 622 A5. Without knowledge of this application, the German group working on the Schwalbach GSHP research station (cf. chapter 3.3) in 1987 successfully tried a similar approach in practice for the conference room of Helmut Hund GmbH in Wetzlar (figure 26). The brine in summertime was circulated by a small pump through the BHE and thus could provide cooling via fan-coil units, without heat pump operation. A year later, another installation using cooling ceiling

The key document identifying future R&D-goals for renewable heating and cooling, the ‘Common Roadmap’ of the RHC-Platform, lists the Key Performance Indicators towards 2020 as given in figure 24. The main areas are addressed: the efficiency of the heat pump and system, the efficiency of the ground-coupling components, and the cost for installation and operation. In the light of the constraints concerning higher efficiency, the issue of cost reduction seems to be the most important target.

instead of fan coils was tested. Meanwhile direct (‘passive’) cooling is widely used in moderate and not too humid climate, and was re-invented several times.

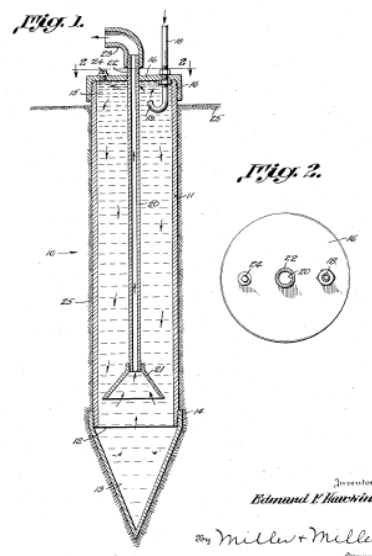

**Figure 25: BHE water cooler of 1934, from US patent 1,981,730**

The other example pertains screw-type or ‘helical’ heat exchangers, also (in most cases inaccurately) called ‘spiral’ or ‘coiled’ BHE (figure 27). Such design was already shown in the patent of Zoelly in 1913, and again in literature from the 1940, e.g. in Kemler (1947). A German patent applied for by U. Hansen in 1977, granted in 1979 under DE 27 00822 C3, showed a screw-type BHE, as did French patent application FR 79 11814 A1 of 1979.

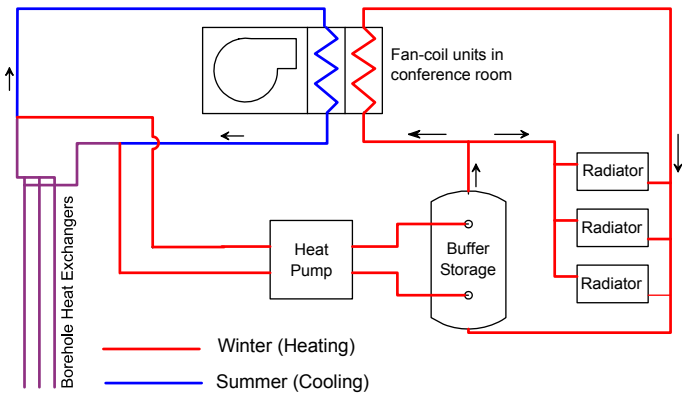

**Figure 26: Direct cooling from BHE at Helmut Hund GmbH, Wetzlar, in 1987 (first published in Sanner, 1990)**

Further attempts were applications DE 31 34177 A1 (by Siemens AG) and DE 31 49636 A1 by O. Schöppler, both in 1981. In 1998 Klemm et al. tried again with application DE 198 56 633 A1 (also as EP 1006331 A1 for Europe a year later). In 2006 a patent was granted to F. Graf under DE 10 2005 020887 B3 for a double-screw-type BHE. In Canada, O. Svec experimented with screw-type BHE in Ottawa clay (Svec and Palmer, 1989). A detailed Swiss report was prepared by Bassetti and Rohner (2005). Eventually design rules for this type of BHE were established in the new draft of VDI 4640-2 from 2015, and new tests with screws/spirals/coils are undertaken e.g. in Italy (Ferrari et al., 2016) and France (Philippe et al., 2016). Two EU-projects launched in 2015 also include work on ‘spiral co-axial vertical BHE’ (project GEOTECH, <http://www.geotech-project.eu/>) and ‘helicoidal BHE’ (project Cheap-GSHP, <http://cheap-gshp.eu/>).

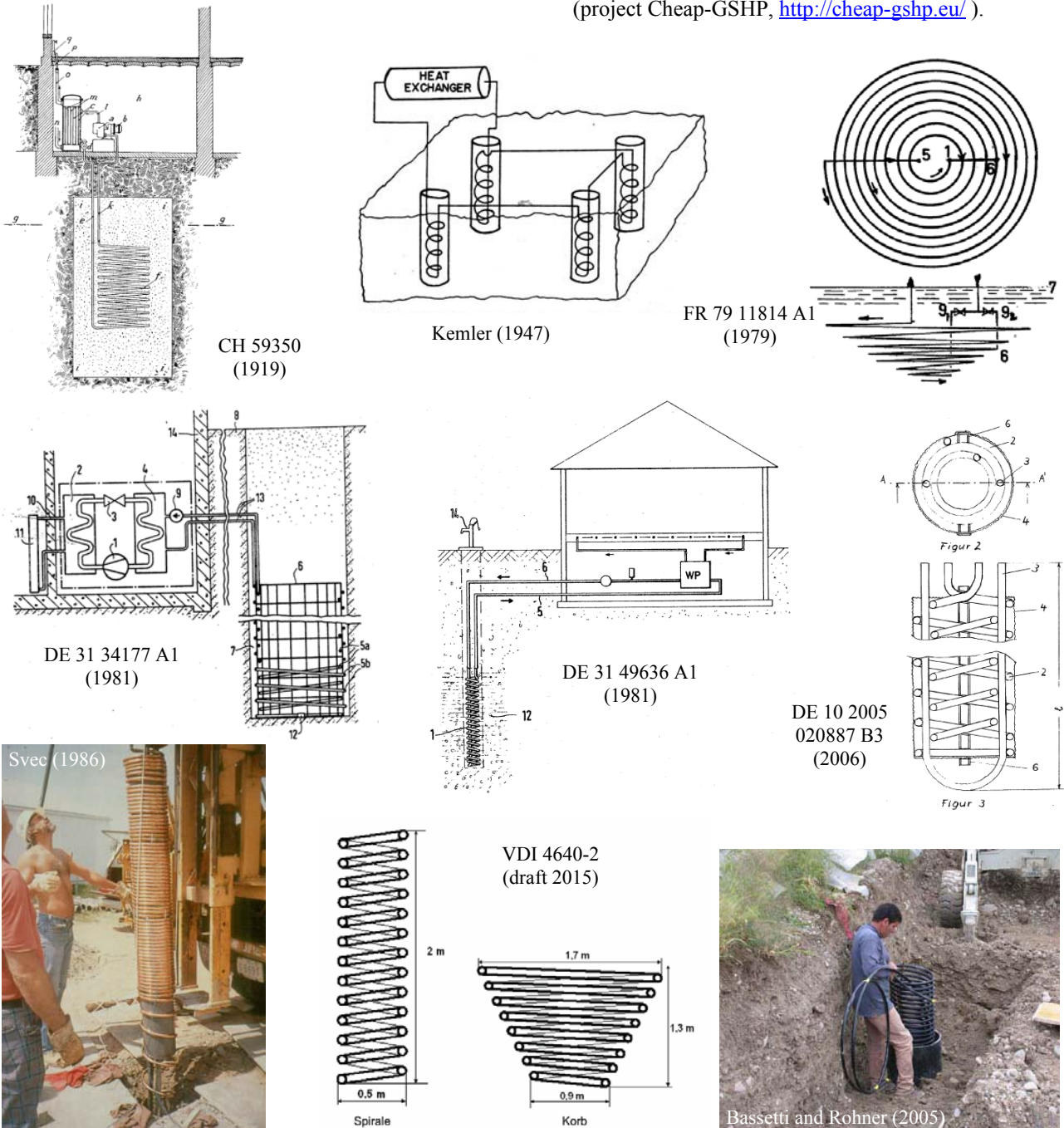

**Figure 27: Examples of screw-type (‘spiral’, ‘coiled’) BHE, also called ‘energy baskets’, spanning a century**

The story of GSHP is far from ending, and both the account of the past will have to be completed, and the new developments reported!

## REFERENCES

- Aghoven, L.T. and Wiskie, K.: Het installeren van een warmtepomp-installatie voor ruimteverwarming met warmteonttrekking aan de aardbodem via verticale bodenwarmte-wisselaars, *Elektrotechniek* 60/3 (1982), 133-139
- Andersson, O.H.: Borring och Dokumentation, Borringsteknik jämte Metodik för Geologisk Datainsamling under Borrnings Gång. *Diss. Thesis 8., Lund Univ., Lund* (1981)
- Andersson, S., Eriksson A. and Johansson, S.: Heat storage in natural ground water basins, *Proc. Int Conf Subs Heat Storage*, Stockholm (1983), 762-767
- Andersson, S.: Ground Heat Storage Technology in Sweden, *Proc. Enerstock 85 Toronto*, Ottawa (1985), 202-207
- Antics, M., Bertani, R. and Sanner, B. (2016): Summary of EGC 2016 Country Update Reports on Geothermal Energy in Europe, *Proc. EGC 2016*, Strasbourg (2016), 1-16
- Aranovitch, E., Hardy, M., Esposito, L., Rizzi, G. and Soma, L. (1985): Performance and analysis of a seasonal heat storage with vertical tubes in the ground, *Proc. 2nd WS on SAHPGCS Vienna*, Ispra (1985), 135-147
- ASME: The Equitable Building Heat Pump System, *Engineering Landmark 46, brochure*, New York (1980)
- Bäckström, B.: General Principles for Earth Heat Pumps, *Proc. Nordic Symposium of Earth Heat Pump Systems*, Göteborg (1979), 24-30
- Bakema, G., Snijders, A.L. and Nordell, B.: Underground thermal energy storage, state of the art 1994, *IEA-ECES*, Arnhem (1995)
- Balke, K.D.: Möglichkeiten und Grenzen des Einsatzes von Grundwasser-Wärmepumpen und Erdwärmesonden, *Z Dtsch Geol Ges* 132 (1981). 691-713,
- Bassetti, S. and Rohner, E.: Projekt Handbuch Erdwärmekörbe - Dokumentation, Auslegung und Anwendungsbeispiele, *Report BFE-Project 101'169* (2005), 1-26
- Bischof, G.: Die Wärmelehre des Innern unsers Erdkörpers, *Verl. Joh. A. Barth*, Leipzig (1837), 1-507
- Boileau, Y., Ferrande, R. and Marie, J.-P.: Les Filières de Stockage Thermique Souterrain en France, Etat Actuel de Developpement et Perspectives, *Proc. Enerstock 85 Toronto*, Ottawa (1985), 161-171
- Bouma, J. and Koppenol, A.: Investigation into a complete earth-to-water heat pump system in a single family dwelling focussing on the application of a vertical subsoil heat exchanger, Report EUR 8077 EN BF, Brussels (1983)
- Brehm, D: Entwicklung, Validierung und Anwendung eines dreidimensionalen, strömungsgekoppelten finite Differenzen Wärmetransportmodells, *Giessener Geologische Schriften* 43, Giessen (1989), 1-120
- Bruck, M., Heindl, W., Koch, H. and Schattschneider, P.: Grundlagen für die Entwicklung eines Dimensionierungsverfahrens für Bodenspeicher, *dbv-Verlag*, Graz (1981)
- Brun, G.: La régularisation de l'énergie solaire par stockage thermique dans le sol, *Revue Générale de Thermique* 44 (1964)
- Buffon, G.L.: Histoire naturelle, générale et particulière, *De l'imprimerie royale*, Paris (1778); cited after: Roger, J.: Buffon, Les Époques de la Nature, *Mémoires du Muséum National d'Histoire Naturelle, C/X*, Paris (1962), 1-495
- Claesson, J. and Johansson, M.: Continuous heat source model for ground heat storage, *SCBR D34:1980*, Stockholm (1980)
- Claesson, J., Efring, B., Eskilson, P. and Hellström, G.: Markvärme, en handbok om termiska analyser, 3 volumes, *BFR T16-18:1985*, Stockholm (1985)
- Claesson, J. and Eskilson, P.: Conductive Heat Extraction to a deep Borehole, Thermal Analysis and Dimensioning Rules, *Energy* 13/6 (1988). 509-527
- Cordier, L.: Essai sur la Température de l'Intérieure de la Terre, *Mémoires de l'Académie Royale des Sciences* 7, Paris (1827), 473-559
- Crandall, A.C.: House Heating with Earth Heat Pump, *Electrical World* 126/19, New York (1946), 94-95
- Delisle, M.A.G.: Modellrechnungen zur Speicherung von Abwärme im flachen Untergrund, *VDI-Berichte* 288, Düsseldorf (1977), 55-63,
- Drafz, H.-J.: Wasser-Wasser-Wärmepumpe in einem Einfamilienhaus, *ETA elektrowärme int* 30/A, Essen, (1972) 25
- Drafz, H.J.: Erdreichsonden als Wärmequelle für Wärmepumpenheizungen, *ETA elektrowärme int* 40/A, Essen, (1982), 222-226
- Dybowski, M.: Wasserrechtliche Gesichtspunkte beim Einsatz von Wärmepumpen, *ETA elektrowärme int* 36/A, Essen, (1978), 111-113
- Egli, M.: Erfahrungen aus dem Betrieb der Wärmepumpen-Heizung im Rathaus von Zürich, *Schweizerische Bauzeitung* 123/8, Zürich (1944), 87-91
- Eickenhorst, H.: Wohnhausheizung mit Wärmepumpen und Erdreich als Wärmequelle, *Technik am Bau* 2/77, Gütersloh (1977). 139-142
- Eriksson, A., Johansson, S. and Åbyhammar, T. (1985): Brunkeberg Aquifer Thermal Energy Storage in Central Stockholm, *Proc. Enerstock 85 Toronto*, Ottawa (1985), 65-67
- Eskilson, P.: Thermal Analysis of Heat Extraction Boreholes, *PhD-thesis, Lund Univ.*, Lund (1987)
- Eugster, W.J.: Erdwärmesonden - Funktionsweise und Wechselwirkung mit dem geologischen Untergrund, *Dissertation ETH Zürich*, Zürich (1991)
- Everett, J.D.: On a method of reducing observations of underground temperatures, *Trans. Royal Society Edinburgh*, XXII/II (1860), 429-439
- Everett, J.D.: On Underground Temperature, *Proc. Belfast Nat. Hist. Soc. for 1873-4* (1873), 41-50
- Ferrari, M.; Barbaresi, A.; Tinti, F.; Brunelli, D.; Benni, S.; Torreggiani, D.; Verdecchia, A.; Bedeschi, E.; Bruno, R. and Tassinari, P.: Performance evaluation of a homemade cylindrical basket heat exchanger, by a multi-sensors monitoring campaign, *Proc. EGC 2016, T-HP-105*, Strasbourg (2016), 1-10



- Fisch, N. and Giebe, R. (1986): Aquifer-Wärmespeicher-Pilotprojekt an der Universität Stuttgart, *Z. Angew. Geowiss.* 7, Giessen (1986), 89-100
- Fordsmann, M.: An Overview of the various Possibilities of Heat Extraction and Heat Delivery for a Water/Water Heat Pump, and an Evaluation of their Technical and Economical Merits, *Proc. Nordic Symposium of Earth Heat Pump Systems*, Göteborg (1979), 155-165
- Ginschel, J.: Betriebsergebnisse einer Erdreich-Wasser-Wärmepumpe, *ETA elektrowärme int.* 35/A, Essen (1977), 332-337
- Goulburn, J.R. and Fearon, J.: Deep Ground Coil Evaporators for Heat Pumps, *Applied Energy* 4 (1978), 293-313
- Goulburn, J.R. and Fearon, J.: Domestic heat pump with deep hole ground source evaporator, *Applied Energy* 14 (1983), 99-113
- Grouvel, F. and Boissavy, C.: Couverture totale des besoins de chauffage et d'eau chaude sanitaire par la géothermie très basse enthalpie assistée par pompe à chaleur, *Proc. Jigastock 88 Versailles, AFME*, Paris (1988), 507-513
- Hadorn, J.C., Chuard, P. and Chuard, D.: The Vulruz project, first experimental results, *Proc. 2nd WS on SAHPGCS Vienna*, Ispra (1985), 15-28
- Hakenbeck, D.: Beheizung eines Einfamilienhauses im Raum Münster mit einer monovalenten Wasser-Wasser-Wärmepumpe, *ETA elektrowärme int.* 37/A, Essen, (1979) 115-117
- Haldin, S., Jansson, P.-E. and Lundkvist, H.: Ecological Effects of Longterm Soil Heat Pump Use, *Proc. Nordic Symposium of Earth Heat Pump Systems*, Göteborg (1979), 14-23
- Hansen, K., Hansen, P. & Ussing, V.: Seasonal heat storage in underground warm water stores, *Report EUR 8914 EN*, Brussels (1984)
- Hellström, G.: Comparison between theoretical models and field experiments for ground heat systems, *Proc. Int Conf Subs Heat Storage*, Stockholm (1983), 102-115
- Hellström, G. and Sanner, B.: Software for dimensioning of deep boreholes for heat extraction, *Proc. Calorstock 94, Espoo*, Helsinki (1994), 195-202
- Hopkirk, R.J. and Gilby, D.J.: Vertical tube earth heat exchangers - the Swiss experience, *Proc. Int. Symp. on Geothermal Energy, Hawaii* (1985), 443-446
- Hultmark, G.: Sunclay - optimized system configurations and economy, *Proc. 2nd WS on SAHPGCS Vienna*, Ispra (1985), 531-549
- Hydén, H.: Aquifer Heat Storage Technology in Sweden, *Proc. Enerstock 85 Toronto*, Ottawa (1985), 80-84
- Iris, P., Viennot, P., Ausseur, J.Y. and Sauty, J.P.: Heat Storage and Heat Pumps on Aquifer: Two Case Studies, *Proc. Enerstock 85 Toronto*, Ottawa (1985), 85-89
- Jäckli, H.: Nappe phréatique comme source froide des pompes à chaleur, *OFEN etude no. 17*, Bern (1980), 155-222
- Jänisch, H.: Erfahrung mit Planung, Bau und Betrieb von Wärmepumpen, Wärmeträger Grundwasser, *ETA elektrowärme int.* 36/A, Essen, (1978), 107-110
- Kangas, M.T., Lund, P.D. and Laitinen, T.: Comparison of Long-Term ATES Experiments to 3-D Computer Simulations, *Proc. Enerstock 85 Toronto*, Ottawa (1985), 90-94
- Katona, O. and Brandner, R.: System analysis of heat pumps with vertical earth heat exchangers, with or without recharging, *Proc. 2nd WS on SAHPGCS Vienna*, Ispra (1985), 191-201
- Katona, O.: Wärmepumpen-Heizsysteme mit vertikalen Bodensonden, *Diss. TU Graz*, Graz (1986)
- Kazmann, R.G.: Exotic Uses of Aquifers, *J. Irrig. Drain. Div., ASCE, 97/IR3*, New York (1971), 515-522
- Kemler, E.N.: Methods of Earth Heat Recovery for the Heat Pump, *Heating and Ventilating, Sept. 1947* (1947), 69-72
- Kircher, A.: *Mundus Subterraneus, 2 Volumes*, J. Jansson & E. Weyerstraten, Amsterdam (1665)
- Kley, W. and Nieskens, H.G.: Möglichkeiten der Wärmespeicherung in einem Porengrundwasserleiter und technische Probleme bei der Rückgewinnung der Energie, *Z Dtsch Geol Ges* 126 (1975), 397-409
- Knoblich, K., Sanner, B. and Klugescheid, M.: Energetische, hydrologische und geologische Untersuchungen zum Entzug von Wärme aus dem Erdreich, *Giessener Geologische Schriften* 49, Giessen (1993), 1-192
- Kupffer, A.T.: Über die mittlere Temperatur der Luft und des Bodens auf einigen Punkten des östlichen Russlands, *Ann. Phys. Chem.* 91, Leipzig (1829), 159-192
- LAWA: Grundlagen zur Beurteilung des Einsatzes von Wärmepumpen aus wasserwirtschaftlicher Sicht, *Länderarbeitsgemeinschaft Wasser*, ZfGW-Verlag, Frankfurt (1980), 1-52
- Lazzarin, R.M. and Schibuola, L.: Some results for the experimental plant (absorption heat pump, energy roof, vertical tube earth storage) of Musile di Piave, Italy, *Proc. 2nd WS on SAHPGCS Vienna*, Ispra (1985), 213-223
- Lebour, G.A.: On the present State of our Knowledge of Underground Temperature, with special Reference to the Nature of the Experiments still required in order to improve this Knowledge, *Trans. North of England Inst. Min. and Mechan. Eng.* XXXI, Newcastle-upon-Tyne (1882), 59-73 and 204-205,
- Leroy, G.: Réponse Transitoire d'un Echangeur Cylindrique Vertical dans le Sol, Characterisation Thermique du Terrain, *Proc. Enerstock 85 Toronto*, Ottawa (1985), 249-253
- Lindblom, U.: Utilization of Underground for Solar and Waste Heat Storage, in: *Bergman, M., Subsurface Space, Proc. of Rockstore '80 Stockholm*, Oxford (1980), 509-514
- Lund, P.D. and Östman, M.B.: A numerical model for seasonal storage of solar heat in the ground by vertical pipes, *Solar Energy* 14 (1985), 351-366
- Mahlbacher, T.: Betrachtungen eines Kollektortyps einer Erdwärmepumpenanlage, *ETA elektrowärme int.* 37/A, Essen, (1979), 368-369
- Mands, E., Sauer, M., Grundmann, E., Langguth, K., Sanner, B. and Gäbler, W.: Stand der technischen Entwicklung oberflächennaher Geothermie in Deutschland, *bbr* 59, 12/08 (2008), 56-65

- Matthey, B.: Development and resorption of a thermal disturbance in a phreatic aquifer with natural convection, *J. of Hydrology* 34 (1977), 315-333
- Matthey, B.: Interseasonal Heat Accumulators in the Ground for Solar Energy, Results of Numerical Simulations, *Proc. Nordic Symposium of Earth Heat Pump Systems*, Göteborg (1979), 236-246
- Matthey, B. and Pillonel, B.: Solar assisted gas heat pump with ground coupled storage for twelve family houses, *Proc. 2nd WS on SAHPGCS Vienna*, Ispra (1985), 203-211
- Meyer, C.F. and Todd, D.K.: Are Heat-Storage Wells the Answer? *Electrical World*, Aug. 15, 1973, New York (1973), 42-45
- Mogensen, P.: Experiences from Earth Heat Pumps in Sweden, *Proc. Nordic Symposium of Earth Heat Pump Systems*, Göteborg (1979), 203-210
- Mogensen, P.: Fluid to Duct Wall Heat Transfer in Duct System Heat Storages, *Proc. Int Conf Subs Heat Storage*, Stockholm (1983), 652-657
- Mogensen, P.: Fullskaleförsök med berg som värmekälla för värmepump i Järfälla, mätning och utvärdering, *BFR R123:1985*, Stockholm (1985), 1-22
- Möller, H.: Berechnung von Wärmepumpenanlagen für Wohnraumbeheizung, bei welchen die Wärme dem Erdreich entzogen wird, *Wärme* 82/4 (1976), 65-72
- Müller, P.: Untersuchungen der Auswirkung des Betriebs von Wärmepumpensystemen auf die Umwelt, *ETA elektrowärme int 36/A*, Essen, (1978), 307-312
- Mull, R. and Schulz, H.: Eichung eines Transportmodells zur Beschreibung der Wärmeausbreitung in einem Grundwasserleiter, *Wasserwirtschaft* 72, (1982), 318-323
- Neiss, J. and Winter, E.R.F.: Analyse der instationären Wärmeleitung zwischen den Wärmetauscherrohren einer Wärmepumpe und dem Erdreich, *Wärme- und Stoffübertragung* 9 (1976), 39-48
- Neiss, J. and Winter, E.R.F.: Erdreich als Wärmequelle, *ETA elektrowärme int 35/A*, Essen, (1977), 323-327
- Nelson, A.: Swedish Borehole Technology, *Proc. Workshop on GSHP, Albany NY, IEA HPC Report HPC-WR-2*, Karlsruhe (1987), 111-112
- Nordell, B.: The Borehole Heat Store at Luleå, Sweden, *Proc. Enerstock 85 Toronto*, Ottawa (1985), 485-489
- Paul, J.: Wärmequellen, die Anwendbarkeit verschiedener Wärmequellen für den Betrieb von Wärmepumpen, Versuch einer Systematik, *Die Kälte* 29/1 (1976), 6-8; 29/2 (1976), 44-48; 29/3, (1976), 82-92
- Pelka, W.: Numerical Method for Calculating Heat Transport in Saturated-Unsaturated Groundwater Flow, *Proc. Int Conf Subs Heat Storage*, Stockholm (1983), 469-475
- Pelka, W.: Computing thermal effects of earth and groundwater heat pumps on the aquifer, *Proc. 2nd WS on SAHPGCS Vienna*, Ispra (1985), 517-527
- Philippe, M.; Chalhoubi, M.; Maragna, C. and Juillac, L.: Experimental studies for improving the performances of compact coil ground heat exchangers, *Proc. EGC 2016, T-HP-198*, Strasbourg (2016), 1-5
- Qvale, B.: The Danish Aquifer Thermal-Energy Storage Program, *Proc. Enerstock 85 Toronto*, Ottawa (1985), 15-19
- Rabbimov, R.T., Umarov, G.Y. and Zakhidov, R.A.: Storage of solar energy in a sandy-gravel ground. - *Geliotekhnika* 7/5, 57-64; Engl. Translation in: *Applied Solar Energy*, New York (1971)
- Reich, F.: Beobachtungen über die Temperatur des Gesteins in verschiedenen Tiefen in den Gruben des sächsischen Erzgebirges, *Verlag J.G. Engelhardt*, Freiberg (1834), 1-205
- Reimann, J.: Erfahrungen mit Wärmepumpen für Heizung und direkte Brauchwassererwärmung im Einfamilienhaus, *ETA elektrowärme int 37/A*, Essen, (1979), 85-90
- Reuss, M. and Schulz, H.: Two years experience with a solar assisted heat pump with ground storage, *Proc. 2nd WS on SAHPGCS Vienna*, Ispra (1985), 149-168
- Rittinger, P.: Theoretisch-praktische Abhandlung über ein für alle Gattungen von Flüssigkeiten anwendbares neues Abdampfverfahren mittelst einer und derselben Wärmemenge, welche zu diesem Behufe durch Wasserkraft in ununterbrochenen Kreislauf versetzt wird, *Verlag Fr. Manz*, Vienna (1855) 1-43
- Rohner, E.: Entwicklung und Stand der Erdsonden-Anlagen in der Schweiz, *Symp. Erdgek WP Rauschholzhausen, IZW-Berichte* 3/91, Karlsruhe (1991), 33-40
- Rosenblad, G.: Earth Heat Pump System with Vertical Pipes for Heat Extraction and Storage. - *Proc. Nordic Symposium of Earth Heat Pump Systems*, Göteborg (1979), 102-110
- Rouvé, G., Kerzel, C. and Pelka, W.: Wärme aus Wasser und Boden, Gesichtspunkte zum Einsatz von Wärmepumpen. *Wasser und Boden* 12, Aachen (1980), 568-571
- Rouvel, L.: Erdreichtemperaturen bei Wärmeentzug mittels Wärmepumpen, *Heizung, Lüftung, Haustechnik* 26/11 (1975), 393-396
- Runesson, K., Wiberg, N.-E. and Andersson, O.: Energy Transport and Energy Storage in Earth analysed by the Finite Element Method, *Proc. Nordic Symposium of Earth Heat Pump Systems*, Göteborg (1979), 226-235
- Rybach, L.: The vertical earth heat exchanger - a small-scale geothermal energy system, *Revista Brasileira de Geofisica* 5 ,(1987), 319-324
- Sanner, B.: Schwalbach Ground Coupled Heat Pump Research Station, *Newsletter IEA Heat Pump Center* 4/4 (1986), 8-10
- Sanner, B., Brehm, D.R. and Knoblich, K.: Erstes Betriebsjahr der Wärmepumpen-Versuchsanlage Schwalbach (1985/1986), *Z. Angew. Geowiss.* 7, Giessen (1986), 43-60
- Sanner, B.: Research on Ground Coupled Systems with vertical heat exchangers, *Proc. Workshop on GSHP, Albany NY, IEA HPC Report HPC-WR-2*, Karlsruhe (1987), 113-117
- Sanner, B.: Ground Source Heat Pump Systems: R&D and Practical Experiences in FRG, *Proc. 3. IEA Heat Pump Conf. Tokyo*, Oxford (1990), 401-409
- Sanner, B.: Erdgekoppelte Wärmepumpen - Geschichte, Systeme, Auslegung, Installation. *IZW-Berichte* 2/92, Karlsruhe (1992), 1-328

- Sanner, B. Erdwärme im Naturmuseum St. Gallen, *Geothermische Energie* 7/94 (1994), 11
- Sanner, B.: 50 years of ground-source heat pumping, *Newsletter IEA Heat Pump Center* 13/4 (1995), 4
- Sanner, B.: Kurzer Abriss der Geschichte der Erdwärmeforschung von der Antike bis zum Beginn des 20. Jahrhunderts, *Giessener Geologische Schriften* 56, Giessen (1996), 255-277
- Sanner, B. (ed.): High Temperature Underground Thermal Energy Storage, State-of-the-art and Prospects, *Giessener Geologische Schriften* 67, Giessen (1999), 1-158
- Sanner, B.: Die erdgekoppelte Wärmepumpe wird 60 Jahre alt, *bbr* 56, 12/05 (2005), 60-67
- Sauty, J.P. and Ausseur, J.Y.: Presentation d'un Progiiciel pour l'Evaluation automatisee des Projets de Stockage de Chaleur dans le Sol, *Proc. Enerstock 85 Toronto*, Ottawa (1985), 499-503
- Schär, O.: Die Anwendung der Wärmepumpe zur Heizung von Wohnbauten mit Wärmeentnahme aus dem Erdreich, *Bull. SEV/VSE* 68/4 (1977), 182-184
- Schaumann, G. and Hoffmann, K. (1986): Vertikale Erdwärmetauscher als Wärmequelle für eine Wärmepumpe zur Beheizung eines Ausstellungs- und Bürogebäudes, *Z. Angew. Geowiss.* 7, Giessen (1986), 21-28
- Schnell, K.: Wasser-Wasser-Wärmepumpe in einer Apotheke mit Wohnungen in Kall/Eifel, *ETA elektrowärme int* 37/A, Essen, (1979), 122-123
- Schulz, H.: Sonden-Erdspeicher für Wärmepumpen, *Sonnenenergie und Wärmepumpe* 8/6 (1983)
- Schunesson, H.: Borrning av Värmelager, *Luleå TH, Teknisk Rapport* 1985:24T, Luleå (1985), 1-61
- Schwanner, I. and Hopkirk, R.J.: Die vertikale Erdsonde als Energiebeschaffungssystem, *Bundesamt f. Energiewirtschaft, Studie EPA Nr. 217.184*, Zürich (1982)
- Sowa, G.: Erdreich-Wasser-Wärmepumpe in einem Einfamilienhaus, *ETA elektrowärme int* 32/A, Essen, (1974), 46-48
- Specht, O. (1978): Elektro-Wärmepumpen mit Wärmeträger Erdreich, *ETA elektrowärme int* 36/A, Essen, (1978), 101-104
- Spitler, J.D. and Gehlin, S.: Thermal response testing for ground source heat pump systems - An historical review, *Renewable and Sustainable Energy Reviews* 50 (2015), 1125-1137
- Sun, Y., Li, Q. and Wu, J. (1991): The experiment of storing cold and warm water in aquifer in Shanghai, P.R. China, and its effect, *Proc. Thermastock 91 Scheveningen*, Utrecht (1991), 1.1.1-1.1.7
- Sundberg, J., Thunholm, B. and Johnson, J.: Värmeöverförande egenskaper i svensk berggrund, *BFR R97:1985*, Stockholm (1985), 1-97
- Sundberg, J.: Värmeöverförande egenskaper i svenska jordarter, *BFR R104:1986*, Stockholm (1986), 1-112
- Svec, O.J. and Palmer, J.H.L.: Performance of a spiral Ground Heat Exchanger for Heat Pump Application, *Int. Journal Energy Research* 13 (1989), 503-510
- Svensson, T.: Swedish Research on Environmental Impact of Heat Storage and Absorption in Earth, Water and Rocks, *Proc. Int Conf Subs Heat Storage*, Stockholm (1983), 36-41
- Thomson W.: On the economy of the heating or cooling of buildings by means of currents of air, *Proc Philosophical Soc Glasgow* 1853/III (1853), 269-272
- Thomson, W.: On the Reduction of Observations of Underground Temperature, *Trans. Royal Society Edinburgh*, XXII/II (1860), 405-427
- Tollin, J.: Heat Pump with a Hard Rock Well equipped for Thermal Recharging, *Proc. Enerstock 85 Toronto*, Ottawa (1985), 290-294
- Tollin, J. and Åbyhammar, T. (1986): Bergvärmearläggning med 80 kW värmeeffekt, *BFR R72:1986*, Stockholm (1986), 1-44
- Troedsson, T.: Ecological Effects of Soil-Heat Extraction in Soil and Vegetation, *Proc. Int Conf Subs Heat Storage*, Stockholm (1983), 685-689
- Von Cube, H.-L.: Die Projektierung erdverlegter Rohrschlangen für Heizwärmepumpen, *KI Klima und Kälte* 5/6 (1977), 217-222
- Von Humboldt, A.: Ueber die unterirdischen Gasarten und die Mittel ihren Nachtheil zu vermeiden, Vieweg, Braunschweig (1799)
- Waterkotte, K.: Erdreich-Wasser-Wärmepumpe für ein Einfamilienhaus, *ETA elektrowärme int* 30/A, Essen, (1972), 39-43
- Werner, D. and Kley, W.: Problems of Heat Storage in Aquifers, *J. Hydrol.* 34 (1977), 35-43
- Wijsman, A.J.T.M.: The Groningen Project: 96 Solar Houses with Seasonal Heat Storage in the Soil, *Proc. Enerstock 85 Toronto*, Ottawa (1985), 518-521
- Wilén, P., Rhen, I. and Bäckström, B. (1985): Development of Heat Storage Systems with Vertical Pipes in Earth and Rock, *Proc. Enerstock 85 Toronto*, Ottawa (1985), 300-304
- Wirth, E.: Aus der Entwicklungsgeschichte der Wärmepumpe, *Schweizerische Bauzeitung* 73/42, Zürich (1955), 647-651
- Wolf, F.: Einfamilienhaus mit Wasser-Wasser-Wärmepumpe in Husum, *ETA elektrowärme int* 37/A, Essen, (1979), 113
- WTA: Wärmepumpen-Energiequellen in Theorie und Praxis, company brochure, Worms (1981), 1-61
- Zogg, M.: Geschichte der Wärmepumpe, Schweizer Beiträge und internationale Meilensteine, *Bundesamt für Energie*, Bern (2008)